

# Testing of oilseparator Watercare, NS6, class 2

## Test report

**File number:** 1321579-4/2007

**Carried out for:**  
Watercare ApS  
Drejervænget 1  
5610 Assens

**Key words:** Sewer, oil separator, environmental requirements

**Carried out by:**  
Danish Technological Institute, Pipe Centre  
Gregersensvej  
DK-2630 Taastrup  
Stig Clausen, Consultant  
Ulrik Hindsberger, M.Sc.

**Number of pages:** 9

**Taastrup, 30. April 2007**

## Table of contents

<b>1. TEST.....</b>	<b>3</b>
1.1. TEST SEPARATOR .....	3
1.2. PURPOSE AND SCOPE OF THE TEST.....	3
1.3. TEST SEPARATOR - SAMPLING .....	3
1.4. TEST METHOD .....	3
1.5. CONCLUSION .....	3
SUPPLEMENT 1: TEST RESULTS.....	4
ANALYSIS RESULTS .....	6
SUPPLEMENT 2: DRAWING OF THE OIL SEPARATOR. ....	7
SUPPLEMENT 3: MEASURING FORM FOR TESTING OF OILSEPARATOR.....	8
SUPPLEMENT 4: PICTURES FROM THE TEST.....	9

## 1. Test

### 1.1. Test separator

The Watercare oil separator is a gravimetric separator, nominal size 6 l/s. The separator is made of PEH. Connections are  $\varnothing 160$  and made of PVC. There is one 600 mm access opening. The separator is shown in supplement 2.

### 1.2. Purpose and scope of the test

The purpose of the test is to obtain CE-marking for the separator.

### 1.3. Test separator - sampling

The test separator was sent to the Danish Technological Institute by the manufacturer. The test was carried out the 5. January 2007 in a test set-up described in EN 858-1.

### 1.4. Test method

The test was carried out according to EN 858-1 – March, 2004, Oil separators. – Principles of design, performance and testing, marking and quality control.

#### Results from testing

Reference to section in CEN standard EN 858-1	Requirements clauses in EN 858-1, Table ZA.1	Notes
Reaction to fire	6.2.8	Has not been checked
Watertightness	6.3.2	Pass
Effectiveness	4, 6.3.1, 6.3.3-6.3.8, 6.5	Pass
Load bearing capacity	6.4	Has not been checked
Durability	6.2	Pass

### 1.5. Conclusion

The test shows that the separator meets all relevant requirements in the above standard EN 858-1 according to watertightness and effectiveness. With a flow of 6 l/s, and a content of 95 mg/l of oil in the discharge, the separator meets the requirements of maximum 100 mg/l oil in the discharge for class 2 oil separators. The results are shown in supplement 1.

PIPE CENTRE

30. April 2007

Inge Faldager  
M.Sc.

Ulrik Hindsberger  
M.Sc.

## **Supplement 1: Test results**

### **Reference to section in CEN standard EN 858-1**

The conformity of the test oil separator with the manufacturer's construction drawings has been controlled (supplement 3).

#### **6.3.1 and 6.5.1      Dimensions and conformity of the test separator with the submitted drawings**

The conformity of the test separator with the manufacturer's construction drawings has been controlled. The main dimensions tally with the manufacturer's drawing, a copy of which is enclosed as supplement 2.

#### **6.2                    Materials**

All materials are PEH. All metal parts will be stainless steel. There is no documentation for the properties of the materials. The testing has not included checking specific documentation for the composition of the materials, and no tests of the materials' tightness and resistance to oleaginous liquids have been carried out, except for tests of the separator's efficiency with subsequent observation, which gives no reason for further comment.

#### **6.3.2                   Watertightness of components**

The oil separator was tested by filling water up to 100 mm above the maximum operational level. After 20 min of testing the, oil separator showed no leakage. *Approved*

#### **6.3.3 and 6.3.8      Accessibility and access covers**

All parts of the oil separator are accessible for inspection, maintenance and clearance. *Approved.* The access cover shall comply with EN 124 and shall have odour-tight covers. *The covers has not been checked*

- 6.3.4 Water seals**  
The depth of the water seals of both inlets and outlets is more than 100 mm. *Approved*
- 6.3.5 Inlets and outlets**  
The inlet is 160 mm and the outlet is 160 mm. The pipe minimum nominal diameter for NS 6 oil separators is 125 mm. *Approved*
- 6.3.6 Internal components**  
All internal components have a free passage for cleaning and maintenance. *Approved*
- 6.3.7 Sludge trap**  
There is no sludge trap.
- 6.5.2 Storage capacity of the oil collection area**  
The storage capacity of the oil collection area shall be at least 10 x NS in litres ~ 60 litres. The capacity is more than 150 litres. *Approved*
- 6.5.4 Automatic closure devices**  
The separator was not equipped with an automatic closure device. Watercare has informed that the automatic closure device only will be installed when necessary. *The closure devices has not been checked*
- 6.5.4 Automatic warning devices**  
The oil separator will be provided with automatic warning devices, unless the local authorities allow the use without automatic warning devices. *The automatic warning devices has not been checked*
- 6.5.3 Determination of nominal size, Test procedure**  
The separator is filled with water up to the outlet. The volume of water is called:  $V_K = 2005$  litres.
- Stand-by  
The depth from the surface of the water to the top is measured: 400 mm.
- Flow 6 l/s  
Water at 6 l/s and oil at 30 ml/s (5 ml per l/s) is added for a period of:
- $T_B = 4 \times V_K / Q_w \times 60 = 22$  min minutes (though at least 15 minutes) plus the test period  $T_P$ , which is 5 minutes.  
 $T_B = 27$  minutes.

**Oil is added for 22 minutes + 5 minutes, i.e. a total of 27 minutes.**

In the period  $T_P$ , samples are taken from the outlet directly to the sample bottles in the first minute after  $T_B$ , and then further 4 samples at 1-minute intervals.

The 5 samples are analysed separately, and the test results given as the arithmetical mean value.

**Total quantity of oil: 48,6 liter**

### **Analysis results**

<b>Sample label</b>	<b>Variable</b>	<b>Result</b>	<b>Unit</b>	<b>Method used</b>
Sample glass 050101	Total hydrocarbon	83	mg/l	EN 858-1, 2004
Sample glass 050102	Total hydrocarbon	99	mg/l	EN 858-1, 2004
Sample glass 050103	Total hydrocarbon	104	mg/l	EN 858-1, 2004
Sample glass 050104	Total hydrocarbon	87	mg/l	EN 858-1, 2004
Sample glass 050105	Total hydrocarbon	103	mg/l	EN 858-1, 2004
<b>Arithmetic mean</b>	<b>Total hydrocarbon</b>	<b>95</b>	<b>mg/l</b>	

The following has not been checked:

- 6.2.8 Reaction to fire**  
The reaction to fire must be checked according to clause 8.4 in EN 858-1
- 6.4 Structural stability**  
The structural stability must be checked according to clause 6.4.3 in 858-1
- 6.6 Marking**  
The separator must be marked on the outside of the cover or separator. Operating and maintenance instructions shall be enclosed with the separator on delivery.

**Supplement 2: Drawing of the oil separator**

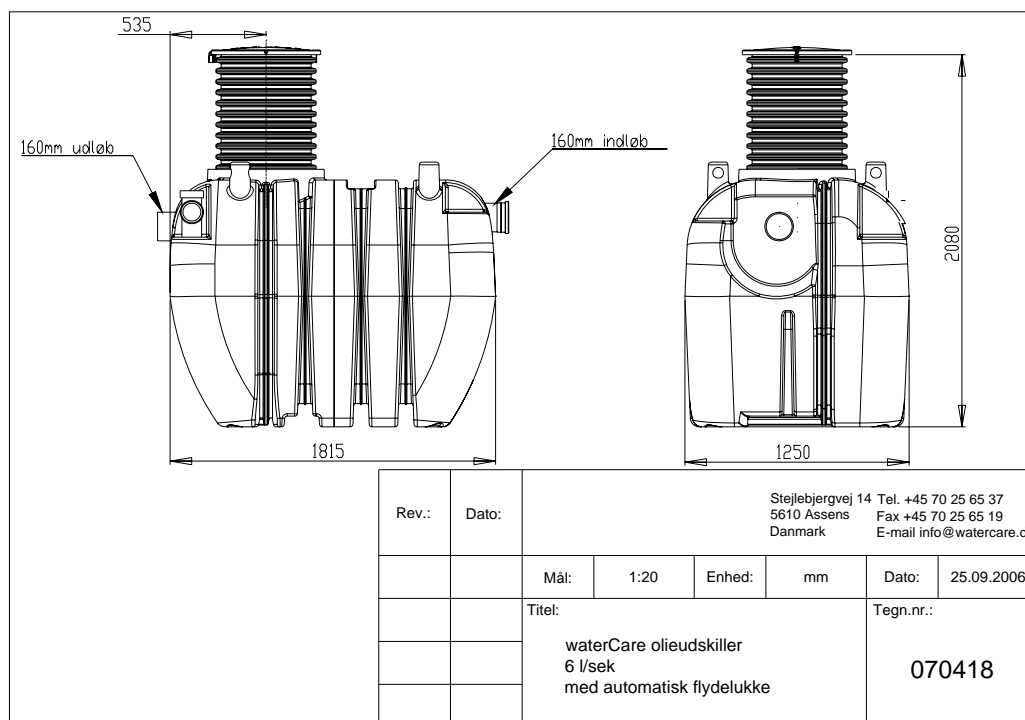

***Supplement 3: Measuring form for testing of oilseparator***

Manufacturer: WaterCare

Date: 05/01-07

Type of tank: Oil separator, NS6, class 2

Type of material: PEH

Measured volume of tank: 2005 liter

Size of inlet: 160 mm

Size of outlet: 160 mm

Diameter of tank: 1240 mm (average)

Height to water level, outlet: 1020 mm

Dimension of access: 535 mm

Wall thickness: 5-7 mm

Type of connection

Inlet: PVC

Outlet: PVC

Signature:



***Supplement 4: Pictures from the test***

